

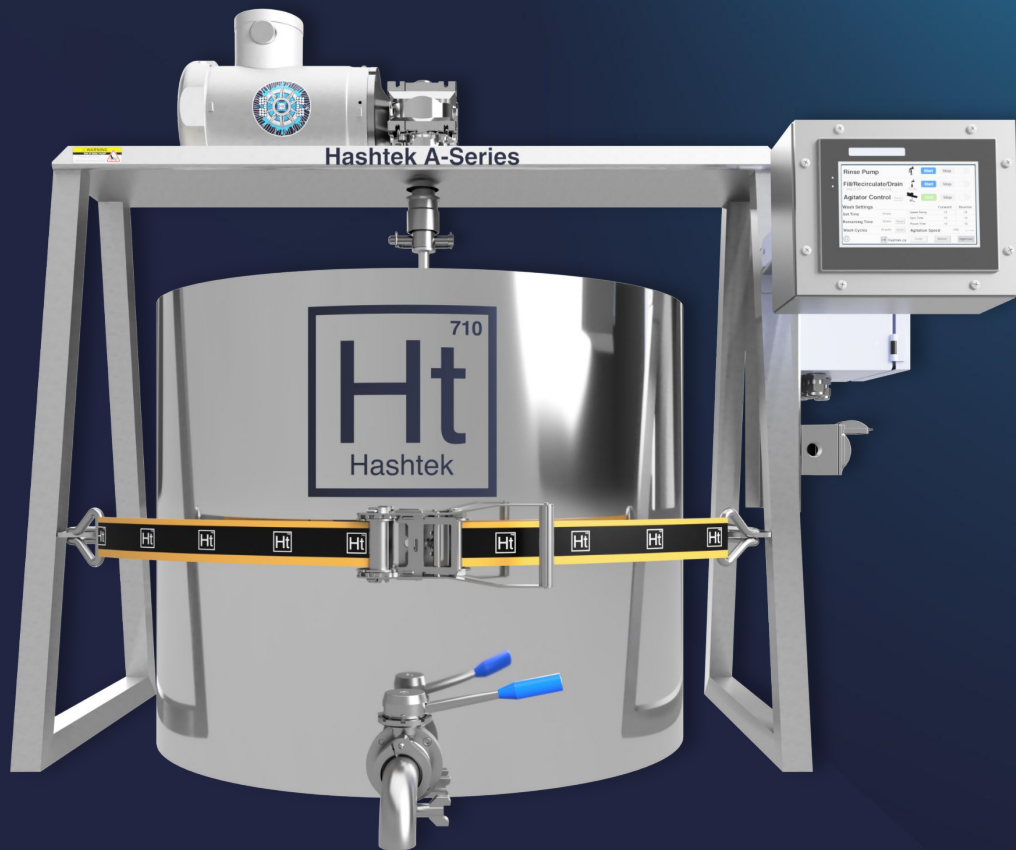

A-SERIES AGITATOR

(Extra Wide)

Commercial Ice Water Hash Extraction System



hashtek.ca

A-SERIES AGITATOR

(Extra Wide)

The **Hashtek A-Series** is engineered to produce the cleanest, highest-quality ice water hash possible. Our top-down agitation system gently mobilizes trichome heads while continuously pulling them away from plant material to preserve structure, color, and terpene integrity.

Unlike bottom-impeller agitators that create destructive vortices, the A-Series promotes true free-flow washing, dramatically reducing contamination and fines.



Why Hashtek Agitation is Different

Top-Down Agitation

- Most washing machines and drill-style mixers use bottom impellers that create strong vortices.
- These vortices can shear trichome heads and macerate plant material, introducing unwanted contamination.
- The A-Series eliminates bottom agitation entirely.
- Instead, the paddle gently mobilizes the wash from above while filtered water continuously pulls trichomes away from biomass.
- **The result is cleaner heads, better color, and improved terpene preservation.**

KEY ADVANTAGES

True Free-Flow Washing

Top-down agitation gently mobilizes trichomes while allowing them to separate naturally from biomass.

Continuous Recirculation Compatible

Designed to work with modern recirculation workflows that keep trichomes moving away from plant material during agitation.

Designed for Real Hash Labs

The A-Series was built around stainless vessels used by professional solventless labs and integrates seamlessly with 30, 50, and 65-gallon washing systems.

Gentle but Powerful

Programmable agitation recipes allow operators to run gentle, medium, or aggressive wash cycles depending on material type and desired output.

Built for Daily Production

Heavy-duty stainless construction, commercial gearboxes, and industrial controls ensure reliable performance for high-volume facilities.



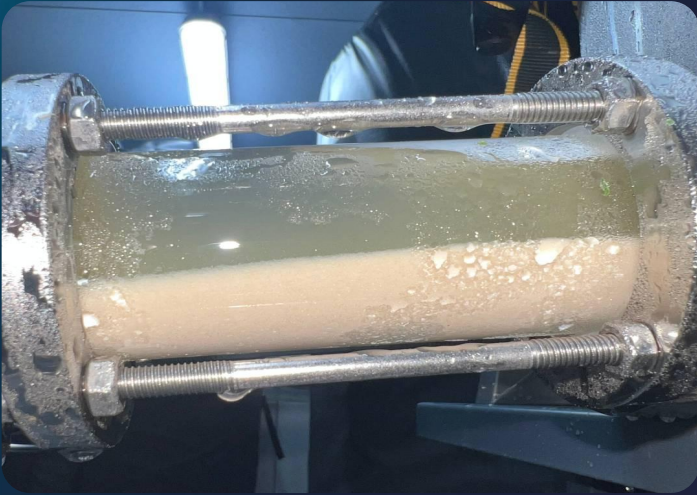

Production Capability

Typical workflow using a 50-gallon tank:

- Process up to 12,000 grams fresh frozen
- 45–60 minute wash cycles
- Three agitation pulls (20 minutes each)

The A-Series dramatically reduces labor while increasing throughput compared to hand washing.



Compatible Washing Systems

The A-Series works with stainless vessels ranging from:

- 25 gallon
- 30 gallon
- 44 gallon
- 50 gallon
- 65 gallon

Adapters and alternate paddles ensure the agitation paddle remains perfectly centered regardless of tank size.



DESIGNED BY HASHMAKERS

Hashtek equipment is built by people who actually wash hash.

Every design decision — from paddle geometry to agitation programming — was developed through real-world solventless production.

FEATURE BREAKDOWN

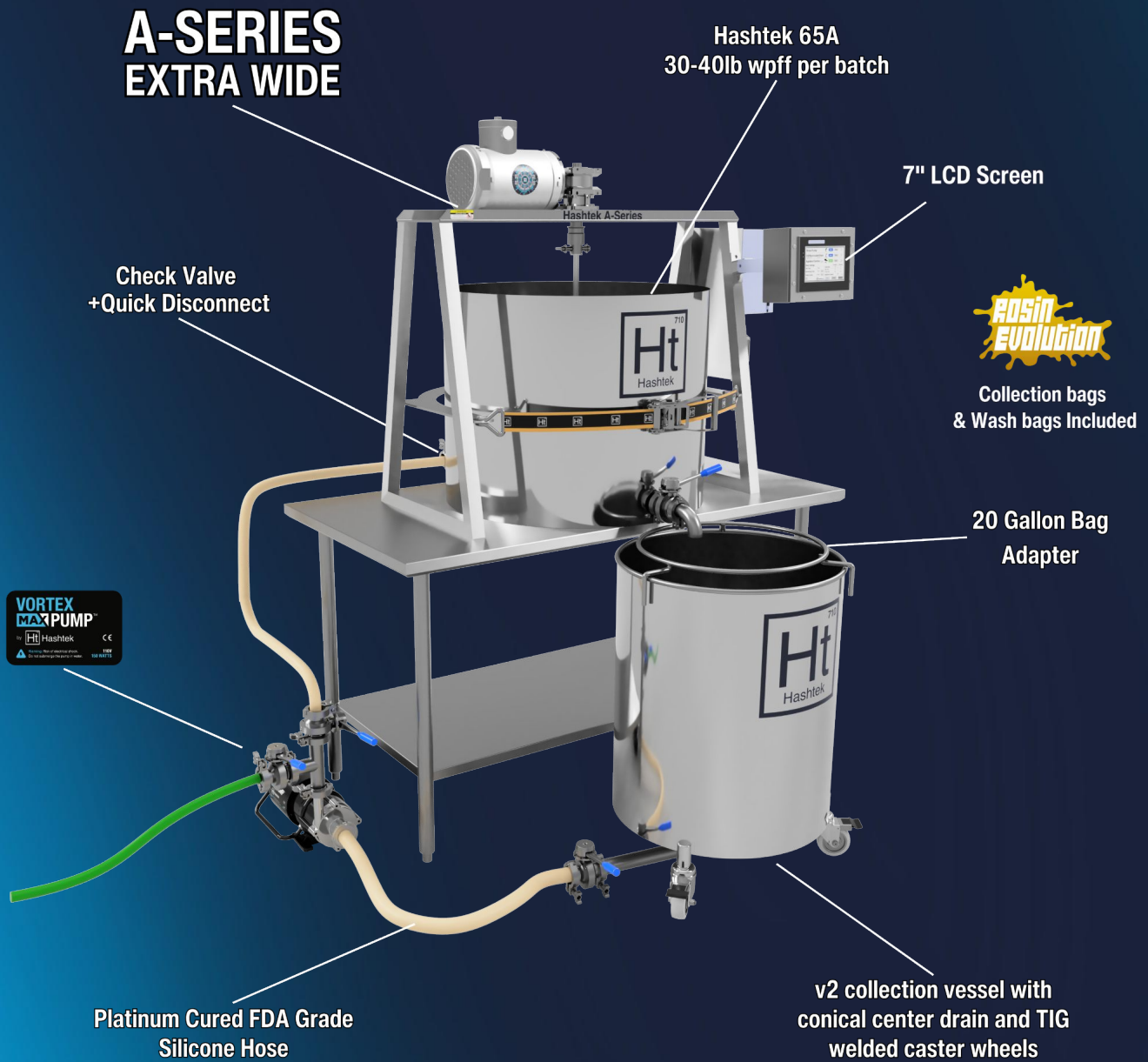

TECHNICAL SPECIFICATIONS

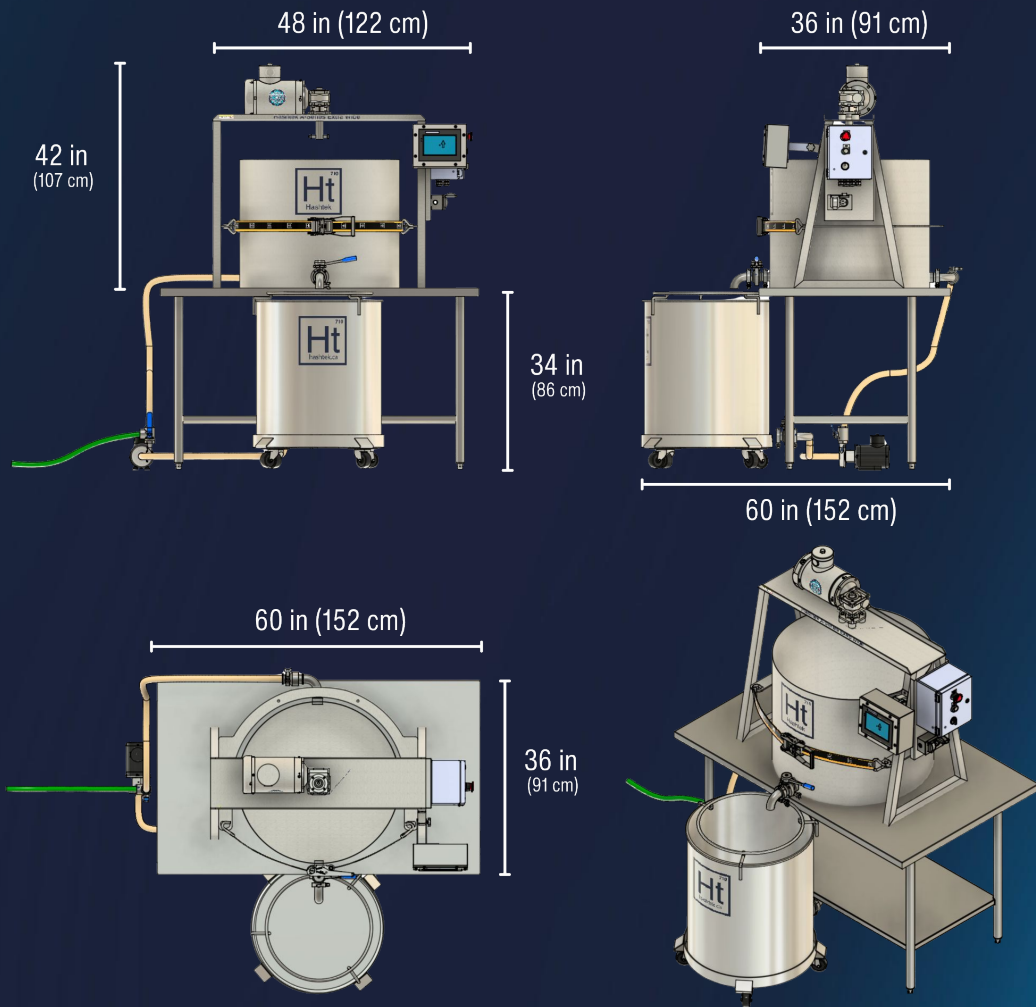

VOLTAGE	OPTIONAL VOLTAGE	MOTOR	FRAME
115V Single Phase (recommended)	230V Single Phase	Stainless Steel Washdown Motor	304 Stainless Steel TIG Welded
	CONTROLS	WEIGHT	CONNECTIONS
	7" LCD Touch Screen or Analog Control	110 lbs (agitator only)	1.5" Sanitary Tri-Clamp



ANALOG 2.1 vs LCD

Two control philosophies. One goal - consistent, high-quality wash.

Choose between precision-driven digital control or simplified analog workflow

ANALOG CONTROL 2.1

Simple. Reliable. Dialed workflow.

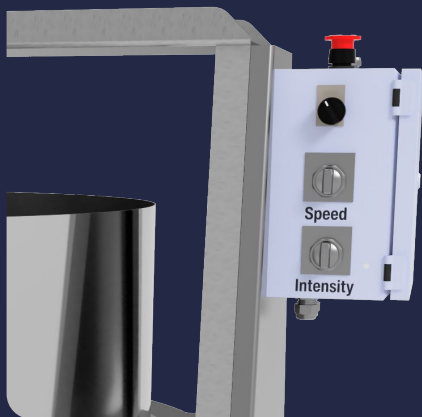

Dual dial system (speed & intensity)

Proprietary scaling of spin time, pause time, and ramp

Designed for **intuitive operation** with minimal learning curve

Front-facing controls for tight lab layouts

Best For:

- Operators who value simplicity
- Fast onboarding/training
- Cost-conscious setups
- Consistent repeatable washes without overthinking

LCD 7" CONTROL

Maximum control. Full customization.



7 independent points of agitator control

Recipe-based wash programs

User-defined gentle/medium/aggressive profiles

Dual pump control (rinse and recirculation)

Ideal for GMP and **process standardization**

Best For:

- Advanced operators
- Multi-strain / multi-process workflows
- Labs requiring precision + repeatability
- Dialing in edge-case material

Electrical Requirements

VOLTAGE	FLA	MCA	PLUG
115V	10A	13A	NEMA 5-15
230V	8A	11A	EU Type C / NEMA L6-15

Control System

The A-Series agitation system allows full control of wash dynamics.

Adjustable parameters include:

- agitation speed
- forward / reverse timing
- ramp speed
- pause intervals
- automated agitation recipes

Three built-in wash profiles:

- Gentle
- Medium
- Aggressive

Custom recipes can also be saved.

Auxiliary Pump Control

The LCD control panel can operate up to two auxiliary pumps directly from the agitator control system.

This allows operators to control:

- rinse pumps
- recirculation pumps

without additional control panels.

Construction

- 304 stainless steel frame
- TIG welded sanitary construction
- stainless washdown motor
- commercial gearbox
- quick-release hybrid paddle
- emergency stop safety button

Tank Compatibility

Compatible with:

- 25 gallon tanks
- 30 gallon tanks
- 44 gallon tanks
- 50 gallon tanks
- 65 gallon tanks

Smaller tanks use bracket adapters and alternate paddles to maintain proper paddle positioning.

Dimensions

Agitator Only:

- 48" L x 21" W x 42" H



Recommended System Pairings

The A-Series is commonly paired with:

- Hashtek agitation tanks
- Hashtek v2 collection vessels
- Hashtek Vortex recirculation pumps
- sanitary tri-clamp plumbing systems

For complete turnkey washing systems, see:

- Hashtek Legendary Bundle
- Hashtek Epic Bundle

MADE IN CANADA

All Hashtek A-Series agitators are designed and assembled in Canada using commercial-grade components built for continuous production environments.

